

Rotary blade level indicator for solids

Operating Instructions

Index	Page
Safety instructions	02
Operating instructions	
1. Specification	03
1.1 Intended use	
1.2 Function	
1.3 Technical data	
1.4 Materials	
1.5 Dimensions	
2. Installation	05
2.1 Preparing for use	
2.2 Mechanical connection	
2.3 Electrical connection	06
3. Use	06
3.1 Commissioning	
3.2 Normal operation	
3.3 Inexpert handling	
4. Maintenance, servicing and spare parts	06
4.1 Maintenance	
4.2 Servicing	
4.3 Spare parts	
5. Storage	06
6. Disposal	06



- **Read these Safety instructions before using the device for the first time and follow the Operating instructions.**

Safety instructions

1. The installation, initial operation and maintenance should only be carried out by a qualified expert with electrical know-how.
2. Comply with the local and statutory rules and/or the VDE0100.
3. Before electrical connection, check the specifications on the data plate and the technical data of this manual.
4. A fuse must be connected in series to the supply voltage, according to the Standard and Normative documents.
5. Protect the signal contacts of the limit switch against voltage peaks when inductive or capacitive loads are connected.
6. Do not remove the Plastic protection inside the housing. It is a protection used to protect the motor-gear from the cables.
7. The device may be put into operation only if the electrical connection is correct. To secure the type of protection, the sealing cap and the gasket must be placed correctly and the screw nut of the cable gland has to be fixed and fastened to the cable entry.
8. The earth connection of the device has to be installed in such a way that mechanical damage will be excluded.
9. Protect the controller from vibration and shakes. The vibration can provoke premature damage to the controller and may become useless.
10. The blade must not be hit by the filling stream. To avoid this, deflect the filling stream or install a deflection screen or a protection roof. It is also recommended to install a protection roof when the controllers are used as empty-indicator or medium-indicator in silos where vaults could be formed or where high loads above it could exist.
11. Avoid the installation of standard devices in ambient with vapour or with several changes of temperature. There are specific models for these applications with different sealings rings and bearings that can extend the lifetime of the device.
12. Ask for rotary levels with the special sealing ring made of Stainless Steel-PTFE-Viton in applications with aggressive products or with micronized bulk solids.
13. The connections of the single components as like as blade, shaft, extension, anti-buckling protection, etc. are permissible only with the attached pins.
14. Switch off the power supply, before disconnecting the device.

Operating instructions

1. Specification

1.1 Intended use

The rotary blade level indicator F9 observes the filling level as a limit switch. It can be used as indicator for dusty and powdery, granulated and grainy bulk goods and are appropriated due to the range of models and blades to control the level of bulk solids like dust, flour, grain, sand, plastic, etc. with a bulk density between 0.01 to 2 t/m³. Although the characteristics of the product, humidity, conductivity, grain size, etc. change, any adjustment is needed

These devices are used to control the level in silos, containers, bunkers and they can be installed horizontally or vertically. For vertical mountings there are rope shafts up to 10 m could be made depending on the product to control.

1.2 Function

The rotating measuring blade, projecting into the silo or container, is driven by a gearmotor. If the bulk material reaches the measuring blade, the rotation will be hindered and it will be stopped. The return torque turns the pivoted motor from its end position and actuates the signal switch. A second switch turns off the motor off.

If the filling level of the bulk material sinks, the blade becomes freely again and a spring will turn the motor back into its original end position. Thereby the motor will be turned on again and the signal switch will be switched back.

1.3 Technical data

Manufacturer	Talleres Filsa, S.A.U.
Address	Bernat Metge, 33 08100 Mollet del Vallès (Barcelona)
Name	Rotary blade indicator
Type	F9-... ref. 91...
Measuring blade speed	1 or 5 rpm depending on the model
Switching voltage	Standard 230 V AC (50 ... 60 Hz) (Under request 115 V AC, 48 V AC, 24 V AC, 24 V DC due to a converter)
Power consumption	4 VA in AC; 4 W in DC
Density of the product	0.01 t/m ³ ... 2 t/m ³
Maximum pressure	-0.5 bar ... +1 bar (Under request up to +5 bar with sealing ring of Stainless Steel-PTFE-Viton)
Cable entry	2 of M20x1.5
Maximum voltage of contact	4 V DC ... 250 V AC
Switching function	1 NO + 1 NC
Capacity of the contact	1 mA / 4 V DC ... 2 A / 250 V AC (for resistive loads)
For inductive or capacitive loads reduce at 50%	
Bulk goods temperature	-20 °C ... +80 °C (Under request up to +150 °C)
Ambient temperature	-20 °C ... +70 °C

Type of protection

IP66 according DIN EN60529

Weight

1.2 kg ... 5 kg depending on the model

1.4 Materials

Housing

Aluminium, RAL 7001 coated

Process connection

G 1 " 1/4 of Aluminium or G 1 " S.S. depending on the model

Flange connection

Aluminium, Zincated Steel or S.S. depending on the model

Measuring blade

S.S. 1.4301, shaft 1.4305

(Under request special models of S.S. 1.4401, Plastic or Gummy)

Sealing ring

NBR

(Under request Stainless Steel-PTFE-Viton)

Rope shaft

Stainless Steel

Rod shaft

Stainless Steel

Protection tube shaft

Zincated Steel

(Under request Stainless Steel)

1.5 Dimensiones

Approximate measures are given in mm.

F9-D

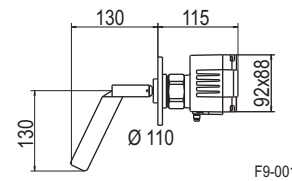

F9-125 or 180

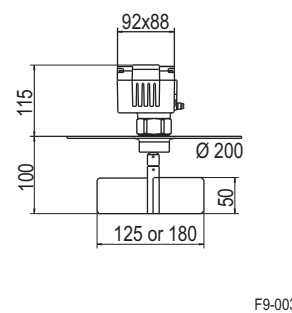

F9-125 or 180 UF with pendulum shaft extension

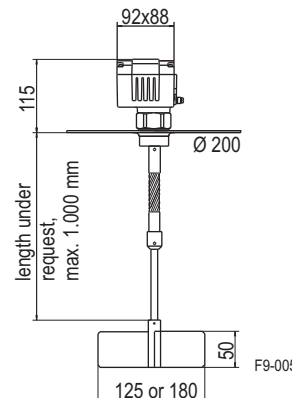

F9-DR

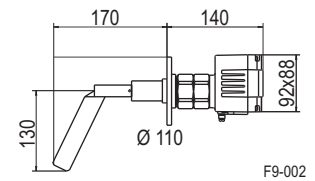

F9-125 or 180 with pendulum shaft (UF)

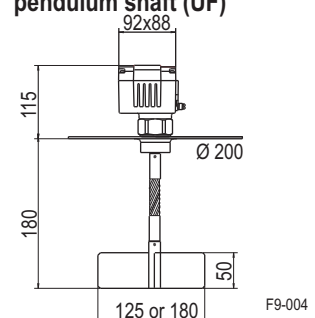

F9-125 or 180 UFM shaft extension with protecting tube

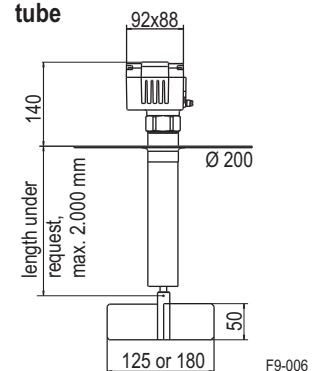



F9-69

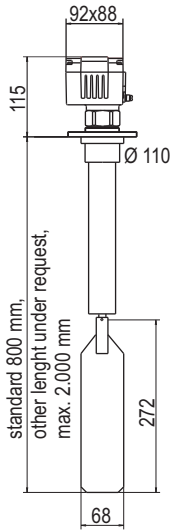

F9-007

F9-C: standard according drawing
F9-C 69: model with blade 69 and flange A-25-110

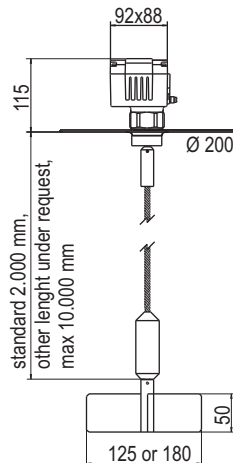

F9-008

F9-P or F9-PR:
 blade speed 5 rpm

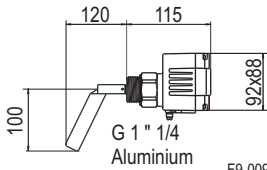

F9-009

F9-M:
 blade speed 5 rpm

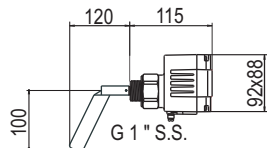

F9-010

Flange connection

Threaded flange in all models G 1 " 1/4 female.

"H" Flanges in Zincated Steel

"A" Flanges in Aluminium

"I" Flanges in Stainless Steel

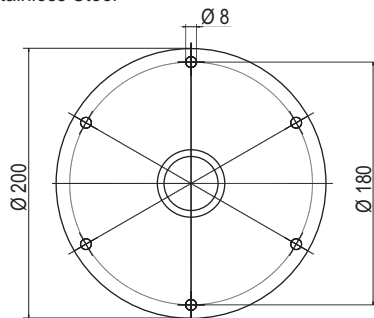

H-25-200

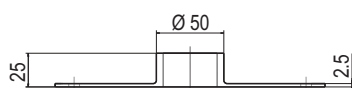

F9-011

H-50-200

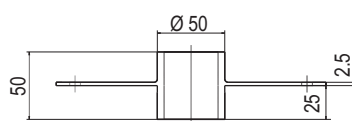

F9-012

I-25-200

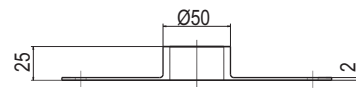

F9-013

I-50-200

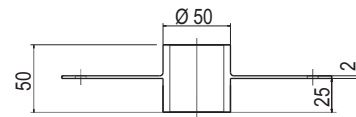

F9-014

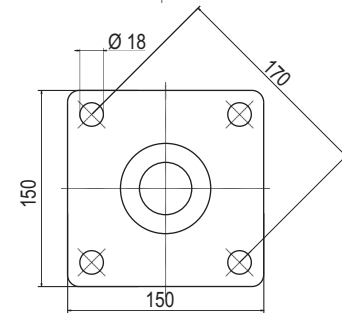

AC-25-150

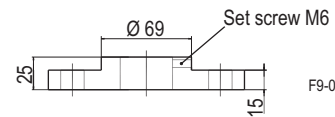

F9-015

AC-50-150

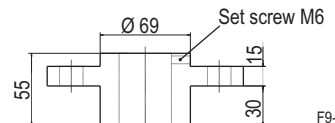

F9-016

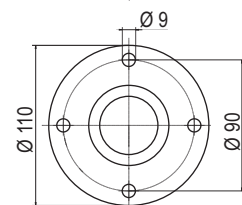

A-25-110

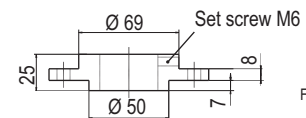

F9-017

A-50-110

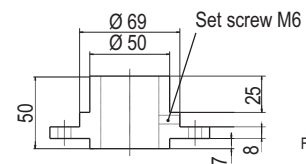

F9-018

I-25-110

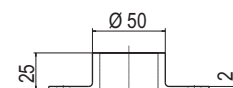

F9-019

I-50-110

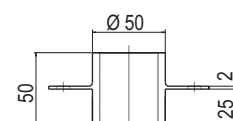

F9-020



Measuring blades

Diagonal blade F9-DR and models with shaft

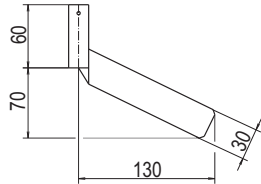

F9-021

Diagonal blade F9-D

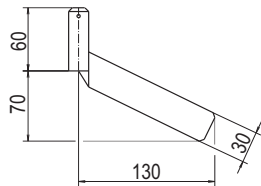

F9-022

Diagonal blade F9-P and F9-M

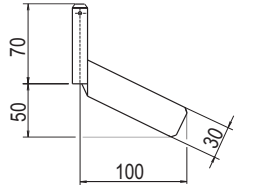

F9-023

Blade X F9-125 or F9-180

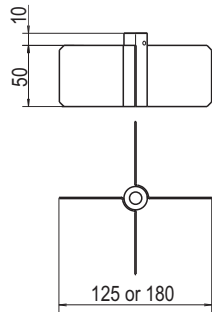

F9-024

F9-69 blade

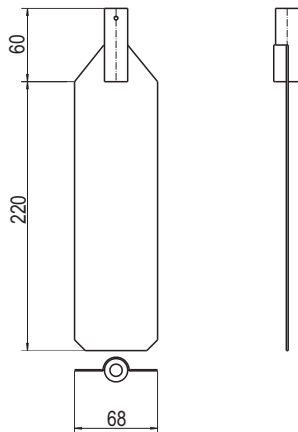

F9-025

Blade T F9-125 or F9-180

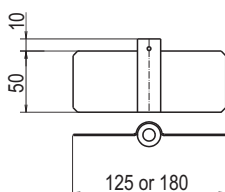

F9-026

Hinged blade Y 30x200

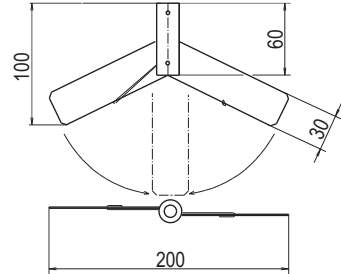

F9-027

Hinged blade T 30x200

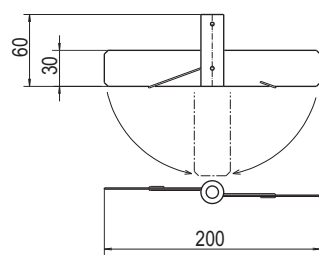

F9-028

2. Installation

2.1 Preparing for use

- Read the Safety instructions and the Operating instructions before using the controller.
- Verify if you got all the parts, the controller, blade with pin and shaft extension if it was requested.

2.2 Mechanical connection

There are models that can be mounted horizontally or vertically into the silo.

The standard form is mounting the device with a flange, drilling holes on the silo to allow the mounting of the controller using screws, rods, fasteners or nuts. If the flange was not requested, the thread is 1 " 1/4 or 1 " male, depending on the model and can be fixed using 1 or 2 nuts or introducing it into a threaded socket with a maximum of 25 mm length. If it is larger, the bulk goods have the possibility to deposit in the thread socket. This could provoke that the device becomes useless.

After the mounting is done, the housing could be turned in order to face the cable gland correctly.

Protection roof

The blade must not be hit by the filling stream. To avoid this, deflect the filling stream or install a deflection screen or a protection roof. It is also recommended to install a protection roof when the controllers are used as empty-indicator or medium-indicator in silos where vaults could be formed or where high loads above it could exist.

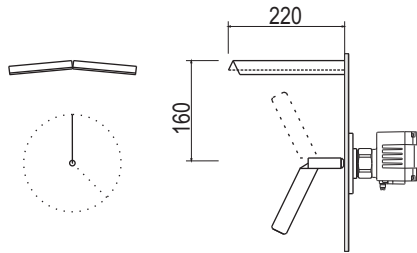

F9-029

2.3 Electrical connection

Connection diagram AC

- ⊕ - Ground
- 1 - Supply voltage
- 2 - Supply voltage
- 4 - Normally closed
- 6 - Normally open
- 3 - Common

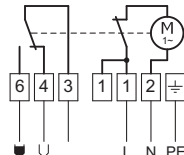

F9-030

Connection diagram DC

- ⊕ - Ground
- 1 - Positive: 24 VDC
- 2 - Negative: 0 VDC
- 4 - Normally closed
- 6 - Normally open
- 3 - Common

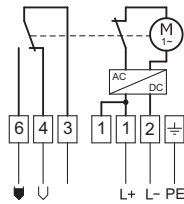

F9-031

Cable gland

- Fasten the cable gland after making the electrical connection.
- Fix and fasten the screw nut of the cable gland to make sure of the water-tightness.

Sensitivity adjustment

For a right adjustment of the sensitivity modify the position of the spring arm using pliers or a screwdriver carefully.

(-) **Light:** Very light bulk goods. Low strain to the spring.

(•) **Medium:** Suitable for almost all bulk goods. Medium strain to the spring.

(+) **Strong:** For sticking bulk goods. Strong strain to the spring.

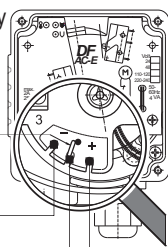

F9-032

3. Use

3.1 Commissioning

- Put the controller into operation only if the installation and the electrical connection have been done correctly.

3.2 Normal operation

- Use the device in its intended application only.
- Comply with the specifications on the data plate and the technical data of this manual.
- If the controller is damaged, disconnect it immediately.
- It is forbidden to make changes to the device. This violates the Normative.

3.3 Inexpert handling

- Ignoring the Safety instructions and the Operating instructions.
- Not intended use.
- Making changes or handling the controller.
- Violation against applicable Law and Standards.
- Using of non original parts.

4. Maintenance, servicing and spare parts

4.1 Maintenance

- If used correctly, no specific maintenance is required.

4.2 Servicing

- Check and review the state of the housing, the blade, shaft extension if it was required and the correct commutation of the electrical contact, as well.

4.3 Spare parts

- Use only original parts.
- The spare parts of the controller can be consulted in the document "R-F9-01".

5. Storage

- Store the controller in a dry and dust-free environment.
- Dismount the shaft together with the blade. Ensure that the shaft of the level indicator with jib extension will not be buckled or bended.

6. Disposal

- Switch off the power supply, before disconnecting the device.
- The controller can be recycled.
- The disposal applies to the valid environmental Guidelines according to the location of the carrier and the local manufacturing conditions.

FILSA constantly strives to improve its products and reserves the right to modify designs, materials and data without prior notice.

Keep this manual for further questions!